



PROPRIETARY NOTE

THIS SPECIFICATION IS THE PROPERTY OF HEI AND SHALL NOT BE REPRODUCED OR COPIED WITHOUT THE WRITTEN PERMISSION OF HEI AND MUST BE RETURNED TO HEI UPON ITS REQUEST



HT12X11-100

Preliminary Product Specification

Rev. P0

LCD SBU

Hynix Semiconductor Inc.



Dept. Displays & Systems

Industriestrasse 16
D-76291 Stutensee / Germany
Tel. +49 7249 910 155 Fax: +49 7249 4232
E-Mail: display@msc-ge.com
Internet: <http://www.msc-ge.com>

SPEC. NUMBER S864-1035	PRODUCT GROUP TFT_LCD PRODUCT	REV. P0	ISSUE DATE 2000:04:25	PAGE 1 OF 24
---------------------------	----------------------------------	------------	--------------------------	-----------------



PRODUCT GROUP

REV.

ISSUE DATE

TFT-LCD PRODUCT

P0

2000.4.25

REVISION HISTORY

REV.	ECN NO.	DESCRIPTION OF CHANGES	DATE	PREPARED
P0	-	Initial Release	APR. 25, '00	H.N. YIM

SPEC. NUMBER

S864-1035

SPEC. TITLE

HT15X11-100 Product Specification for TFT-LCD

PAGE

2 OF 24

	PRODUCT GROUP	REV.	ISSUE DATE
	TFT-LCD PRODUCT	P0	2000.4.25

Contents

	Page
1.0 General Description	4
2.0 Absolute Maximum Ratings.....	5
3.0 Electrical Specifications.....	6
4.0 Optical Specifications.....	7
5.0 Interface Connection	9
6.0 Signal Timing Specification	12
7.0 Signal Timing Waveforms	13
8.0 Input Signals, Display Colors & Gray Scale of Colors	15
9.0 Power Sequence	16
10.0 Mechanical Characteristics	17
11.0 Reliability Test	18
12.0 Handling & Cautions.....	19
13.0 Packing Information	19
14.0 Appendix	20

SPEC. NUMBER S864-1035	SPEC. TITLE HT12X11-100 Preliminary Product Specification for TFT-LCD	PAGE 3 OF 24
---------------------------	---	-----------------

1.0 GENERAL DESCRIPTION

1.1 Introduction

HT12X11-100 is a color active matrix TFT LCD module using amorphous silicon TFT's (Thin Film Transistors) as an active switching devices. This module has a 12.1 inch diagonally measured active area with XGA resolutions (1024 horizontal by 768 vertical pixel array). Each pixel is divided into RED, GREEN, BLUE dots which are arranged in vertical stripe and this module can display 262,144 colors. The TFT-LCD panel used for this module is a low reflection and higher color type. Therefore, this module is suitable for notebook PC. The DC/AC inverter for back-light driving is not built in this model.

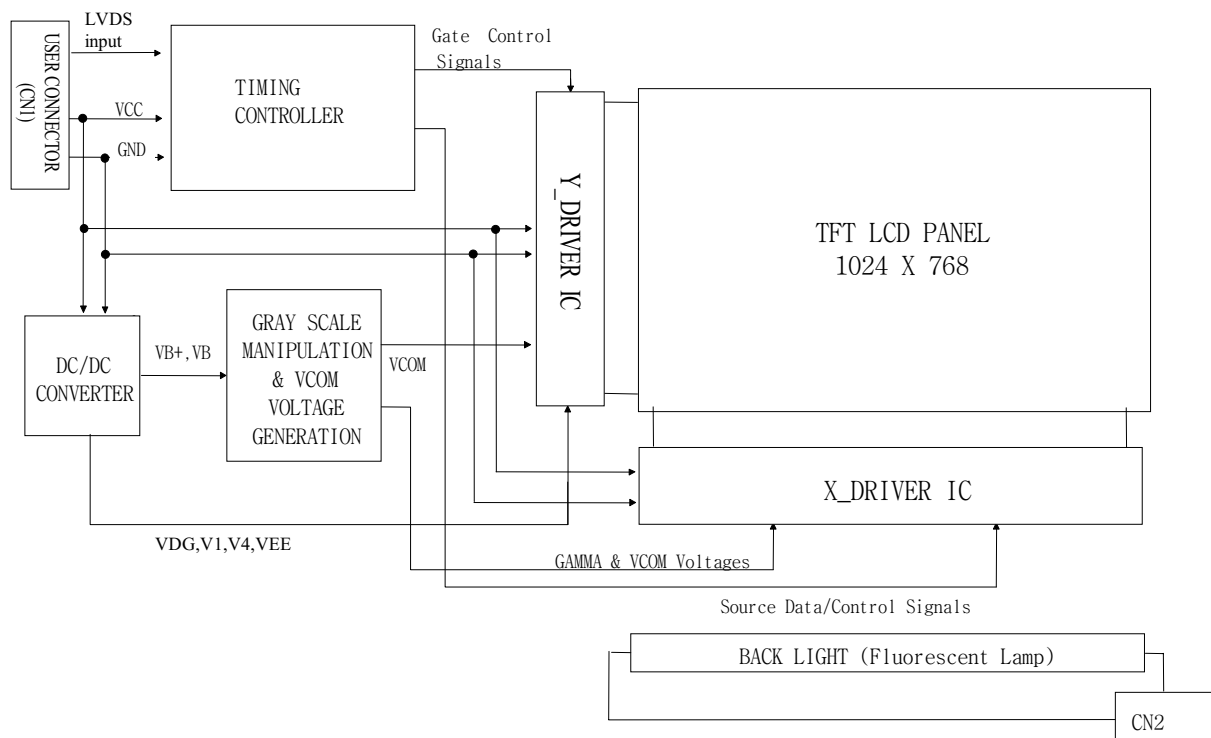

1.2 Features

- Low driving voltage and low power consumption
- Thin and light weight
- 3.3 V power supply
- 1 Channel LVDS Interface
- Single CCFL (Bottom side/Horizontal Direction)
- 262,144 colors
- Data enable signal mode
- Side Mounting Frame

1.3 General Specification

SPEC. NUMBER

S864-1035

SPEC. TITLE

 HT12X11-100 Preliminary Product Specification for
TFT-LCD

PAGE

4 OF 24

	PRODUCT GROUP	REV.	ISSUE DATE
	TFT-LCD PRODUCT	P0	2000.4.25

<Table 1. General Specification>

Parameter	Specification	Unit	Remarks
Active area	245.8 (H) * 184.3 (V)	mm	
Number of pixels	1024 (H) * 768 (V)	pixels	
Pixel pitch	0.240 (H) * 0.240 (V)	mm	
Pixel arrangement	RGB Vertical stripe		
Display colors	262,144	colors	
Display mode	Normally white		
Dimensional outline	261.0 ± 0.5 (H) * 199.0 ± 0.5 (V) * 5.6 (D) typ./ 5.9 (D) max.	mm	Note 1
Weight	400 typ.	g	
Back-light	CCFL, Horizontal-lamp type		Note 1

Note 1: CCFL (Cold Cathode Fluorescent Lamp)

2.0 ABSOLUTE MAXIMUM RATINGS

The followings are maximum values which, if exceed, may cause faulty operation or damage to the unit.

< Table 2. Absolute Maximum Ratings>

Parameter	Symbol	Min.	Max.	Unit
Power Supply Voltage	V_{DD}	- 0.3	+ 4.6	V
Logic Supply Voltage	V_{IN}	- 0.3	$V_{DD} + 0.3$	V
Operating Temperature	T_{OP}	0	+ 50	°C
Storage Temperature	T_{SP}	- 20	+ 60	°C

3.0 ELECTRICAL SPECIFICATIONS

SPEC. NUMBER S864-1035	SPEC. TITLE HT12X11-100 Preliminary Product Specification for TFT-LCD	PAGE 5 OF 24
---------------------------	---	-----------------

	PRODUCT GROUP	REV.	ISSUE DATE
	TFT-LCD PRODUCT	P0	2000.4.25

3.1 Electrical Specifications

< Table 3. Electrical specifications >

Parameter		Min.	Typ.	Max.	Unit	Remarks
Power Supply Voltage	V _{DD}	3.0	3.3	3.6	V	Note1
Power Supply Current	I _{DD}		290		mA	Note1
High Level Input Differential Voltage	V _{IH}			+100	mV	Note2
Low Level Input Differential Voltage	V _{IL}	-100			mV	Note2
Back-light Lamp Voltage	V _{BL}		620		V _{rms}	Note3
Back-light Lamp Current	I _{BL}		5.0		mA _{rms}	
Back-light Lamp operating frequency	F _L	40	(55)	70	KHz	Note4 One Lamp
Lamp Start Voltage					V _{rms}	At Ta = 25 °C
						At Ta = 0 °C
Lamp Life		10,000	15,000		Hrs	
Power Consumption	P _D		0.9		W	Typ. @ Color Bar
	P _{BL}		3.1		W	Note5
	P _{total}		4.0		W	

Notes :

1. The supply voltage is measured and specified at the interface connector of LCM. The current draw and power consumption specified is for 3.3V at 25 °C.
2. LVDS common mode voltage, VCM = 1.2 [V].
3. Reference value, which is measured with Samsung Electric SIC-180 Inverter. (V_{BLMIN} is value at I_{BLMIN} and V_{BLMAX} is value at I_{BLMAX})
4. The lamp frequency should be selected as different as possible from the horizontal synchronous frequency and its harmonics to avoid interference which may cause line flow on the display
5. Calculated value for reference (V_{BL} × I_{BL})

4.0 OPTICAL SPECIFICATIONS

SPEC. NUMBER S864-1035	SPEC. TITLE HT12X11-100 Preliminary Product Specification for TFT-LCD	PAGE 6 OF 24
---------------------------	---	-----------------

4.1 Overview

The test of optical specifications shall be measured in a dark room (ambient luminance ≤ 1 lux and temperature = $25 \pm 2^\circ\text{C}$) with the equipment of Luminance meter system (Goniometer system and TOPCONE BM-5) and test unit shall be located at an approximate distance 50cm from the LCD surface at a viewing angle of θ and Φ equal to 0° . We refer to $\theta_{\theta=0}$ ($=\theta_3$) as the 3 o'clock direction (the "right"), $\theta_{\theta=90}$ ($=\theta_{12}$) as the 12 o'clock direction ("upward"), $\theta_{\theta=180}$ ($=\theta_9$) as the 9 o'clock direction ("left") and $\theta_{\theta=270}$ ($=\theta_6$) as the 6 o'clock direction ("bottom"). While scanning θ and/or Φ , the center of the measuring spot on the display surface shall stay fixed. The backlight should be operating for 30 minutes prior to measurement. VDD shall be $3.3 \pm 0.15\text{V}$ at 25°C . Optimum viewing angle direction is 6 o'clock.

4.2 Optical Specifications

<Table 4. Optical Specifications>

Parameter		Symbol	Condition	Min.	Typ.	Max.	Unit	Remark
Viewing Angle range	Horizontal	Θ_3	CR > 10	40			Deg.	Note 1
		Θ_9		40			Deg.	
	Vertical	Θ_{12}		15			Deg.	
		Θ_6		30			Deg.	
Luminance Contrast ratio		CR	$\Theta = 0^\circ$	150	TBD			Note 2
Average Luminance of white		Y_w	$\Theta = 0^\circ$		130		cd/m^2	Note 3
White luminance uniformity		ΔY	IBL = 5mA		1.17	1.33		Note 4
White Chromaticity		x_w	$\Theta = 0^\circ$		0.315			Note 5
		y_w			0.332			
Reproduction Of color	Red	x_R	$\Theta = 0^\circ$		0.571			
		y_R			0.331			
	Green	x_G			0.309			
		y_G			0.522			
	Blue	x_B			0.149			
		y_B			0.132			
Response Time	Rise + Decay	T_r + T_d	$T_a = 25^\circ\text{C}$ $\Theta = 0^\circ$		TBD	80	ms	Note 6
Cross Talk		CT	$\Theta = 0^\circ$			2.0	%	Note 7

Note:

- Viewing angle is the angle at which the contrast ratio is greater than 10. The viewing angles are determined for the horizontal or 3, 9 o'clock direction and the vertical or 6, 12 o'clock direction with respect to the optical axis which is normal to the LCD surface. (see FIGURE1 shown in Appendix).
- Contrast measurements shall be made at viewing angle of $\Theta = 0^\circ$ and at the center of the LCD surface. Luminance shall be measured with all pixels in the view field set

	PRODUCT GROUP	REV.	ISSUE DATE
	TFT-LCD PRODUCT	P0	2000.4.25

- first to white, then to the dark (black) state . (see FIGURE1 shown in Appendix)
Luminance Contrast Ratio (CR) is defined mathematically as CR = Luminance when displaying a white raster / Luminance when displaying a black raster.
3. Average Luminance of white is defined as arithmetic mean of five measurement points across the LCD surface. Luminance shall be measured with all pixels in the view field set first to white. This measurement shall be taken at the locations shown in FIGURE 2 for a total of the measurements per display.
 4. The White luminance uniformity on LCD surface is then expressed as : $\Delta Y = \text{Maximum Luminance of five points} / \text{Minimum Luminance of five points}$. (see FIGURE 3).
 5. The color chromaticity coordinates specified in Table 4. shall be calculated from the spectral data measured with all pixels first in red, green, blue, and white. Measurements shall be made at the center of the panel.
 6. The electro-optical response time measurements shall be made as shown in FIGURE 4 (shown in Appendix)by switching the “data” input signal ON and OFF. The times needed for the luminance to change from 0% to 90% is Tf and 100% to 10% is Tr.
 7. Cross-Talk of one area of the LCD surface by another shall be measured by comparing the luminance (YA) of a 25mm diameter area, with all display pixels set to a gray level, to the luminance (YB) of that same area when any adjacent area is driven dark (Refer to FIGURE 5).

5.0 INTERFACE CONNECTION

5.1 Electrical Interface Connection

SPEC. NUMBER S864-1035	SPEC. TITLE HT12X11-100 Preliminary Product Specification for TFT-LCD	PAGE 8 OF 24
---------------------------	---	-----------------

The electronics interface connector is a model FI-SEB20P-HF manufactured by JAE or equivalent. The mating connector part number is FI-SE20M or equivalent.

<Table 5. Pin Assignment for the Interface Connector>

Terminal NO.	Symbol	Function
1	VDD1	Power Supply : +3.3V
2	VDD2	Power Supply : +3.3V
3	VSS1	Ground
4	VSS2	Ground
5	RIN0-	Transmission Data of 0 Negative -
6	RIN0+	Transmission Data of 0 Positive +
7	VSS3	Ground
8	RIN1-	Transmission Data of 1 Negative -
9	RIN1+	Transmission Data of 1 Positive +
10	VSS4	Ground
11	RIN2-	Transmission Data of 2 Negative -
12	RIN2+	Transmission Data of 2 Positive +
13	VSS5	Ground
14	RCLK-	Sampling Clock of Negative -
15	RCLK+	Sampling Clock of Positive +
16	VSS6	Ground
17	NC1	No Connection
18	NC2	No Connection
19	NC3	No Connection
20	NC4	No Connection

5.2 LVDS Interface

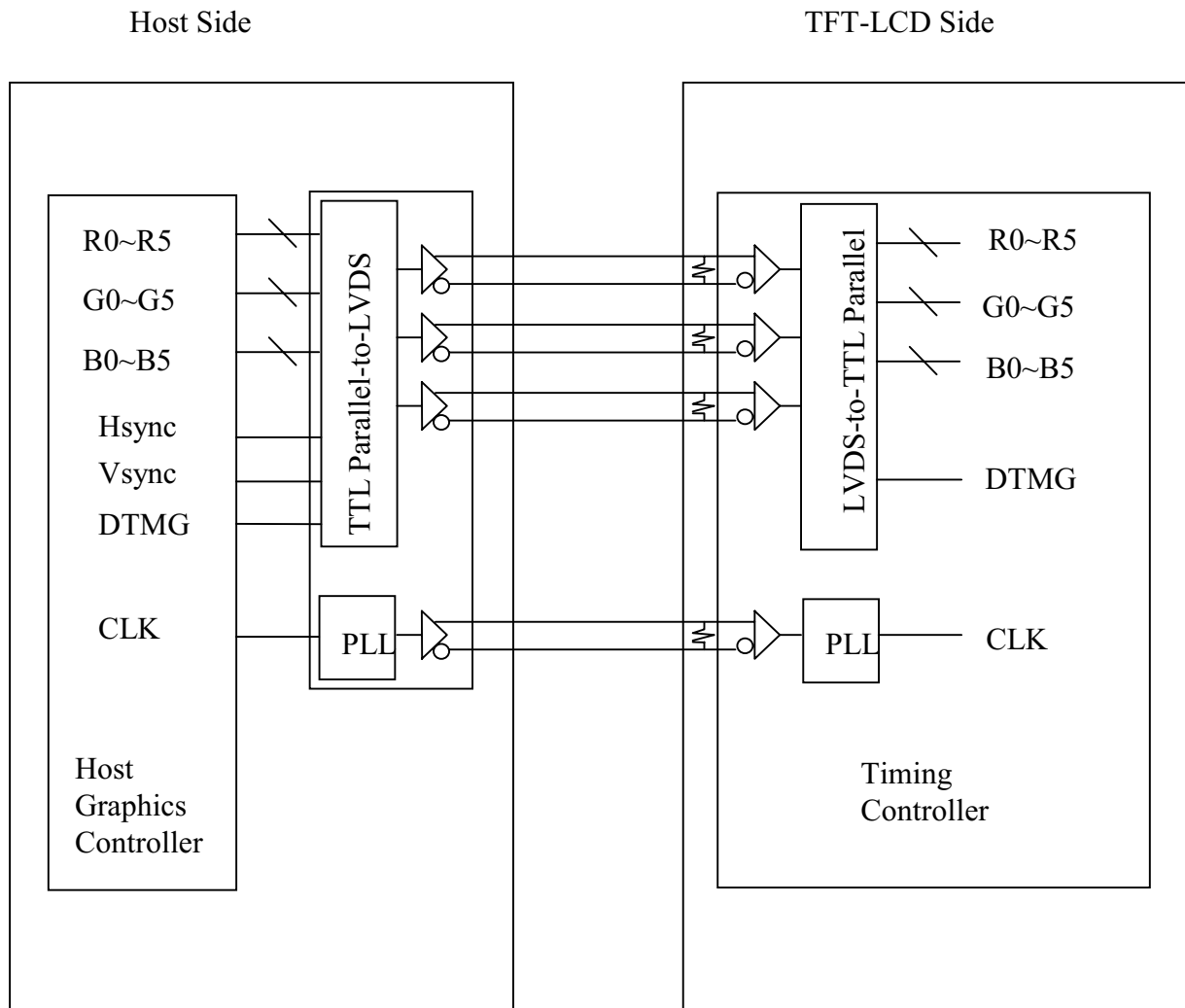

- NOTE : 1) LVDS cable impedance is 100 ohms per signal line when two are used differentially.
 2) Transmitter : TI SN75LVDS84, or equivalent.
 Transmitter is not contained in Module.

5.3 LVDS Input signal

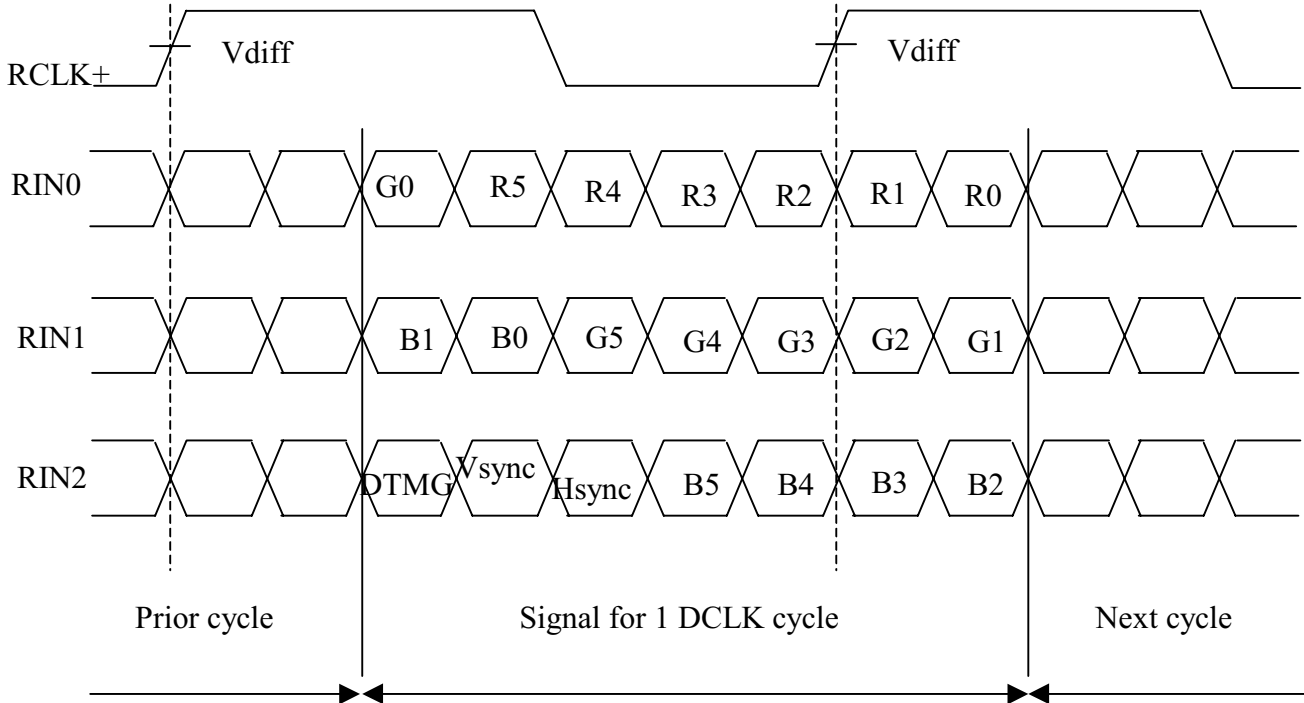

<Table 6. Pin connection in case of using TI SN75LVDS84 >

Input signal	Transmitter	Input signal	Transmitter
DCLK	CLK IN(26)	G4	IN10(10)
R0	IN0(44)	G5	IN11(12)
R1	IN1(45)	B0	IN12(13)
R2	IN2(47)	B1	IN13(15)
R3	IN3(48)	B2	IN14(16)
R4	IN4(1)	B3	IN15(18)
R5	IN5(3)	B4	IN16(19)
G0	IN6(4)	B5	IN17(20)
G1	IN7(6)	Hsync	IN18(22)
G2	IN8(7)	Vsync	IN19(23)
G3	IN9(9)	DTMG	IN20(25)

5.4 LVDS Characteristics

<Table 7. LVDS Characteristics>

Parameter	Symbol	Min.	Typ.	Max.	Units
Potential Difference of High Level Input	VTH			100	mV
Potential Difference of Low Level Input	VTL	-100			mV
Input Common Mode Voltage	VCM	1.0	1.2	1.4	V
Data Setup Time	Tsu	600			pS
Data Hold Time	Thd	600			pS

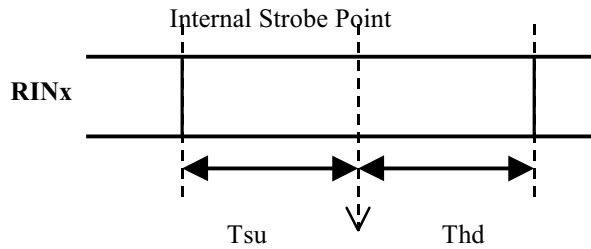

5.5 BACK-LIGHT INTERFACE

The Back-light interface connector is a model BHSR-02VS-1 manufactured by JST or equivalent.

<Table 8. Back-light Electrical Interface>

Terminal No.	Symbol	Function
1	VL	CCFL Power Supply (High Voltage)
2	GL	CCFL Power Supply (GND Side)

6.0 SIGNAL TIMING SPECIFICATION

<Table 9. Signal Timing Specification.>

ITEM	SYMBOL	Min.	Typ.	Max.	Unit	Remarks
Frame Period	t1	TBD	806	TBD	t3	60 Hz
			16.67		ms	
Vertical Display Term	t2	768	768	768	t3	
			15.88		ms	
One Line Scanning Time	t3	TBD	1344	TBD	t5	48.38 kHz
			20.67		us	
Horizontal Display Term	t4	1024	1024	1024	t5	
			15.75		us	
Clock Period	t5		15.38		ns	65 MHz

7.0 SIGNAL TIMING WAVEFORMS

7.1 Vertical Timing Waveforms

SPEC. NUMBER S864-1035	SPEC. TITLE HT12X11-100 Preliminary Product Specification for TFT-LCD	PAGE 12 OF 24
---------------------------	---	------------------

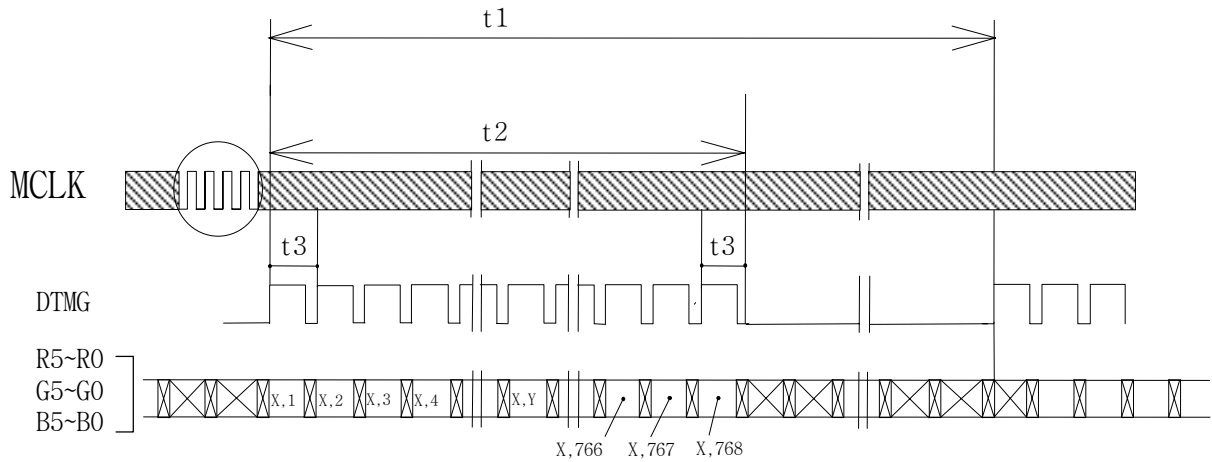

7.2 Horizontal Timing Waveforms

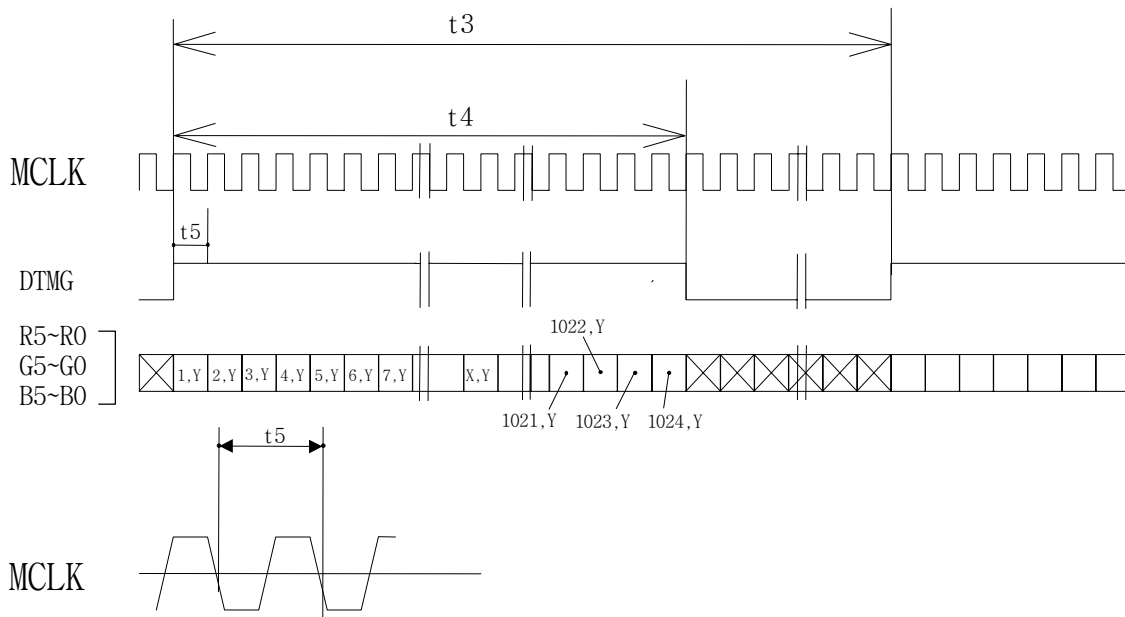

7.3 LVDS Rx Interface Timing Parameter

<Table 10. LVDS Rx Interface Timing Specification>

Item	Symbol	Min	Typ	Max	Unit	Remark
PLL Set	tRPLL	-	-	10.0	msec	
RCLK Period	tRCIP		15.38		nsec	
Input Data 0	tRIP1	-0.2	0.0	+0.2	nsec	
Input Data 1	tRIP0	$tRICP/7 - 0.2$	$tRICP/7$	$tRICP/7 + 0.2$	nsec	
Input Data 2	tRIP6	$2 \times tRICP/7 - 0.2$	$2 \times tRICP/7$	$2 \times tRICP/7 + 0.2$	nsec	
Input Data 3	tRIP5	$3 \times tRICP/7 - 0.2$	$3 \times tRICP/7$	$3 \times tRICP/7 + 0.2$	nsec	
Input Data 4	tRIP4	$4 \times tRICP/7 - 0.2$	$4 \times tRICP/7$	$4 \times tRICP/7 + 0.2$	nsec	
Input Data 5	tRIP3	$5 \times tRICP/7 - 0.2$	$5 \times tRICP/7$	$5 \times tRICP/7 + 0.2$	nsec	
Input Data 6	tRIP2	$6 \times tRICP/7 - 0.2$	$6 \times tRICP/7$	$6 \times tRICP/7 + 0.2$	nsec	

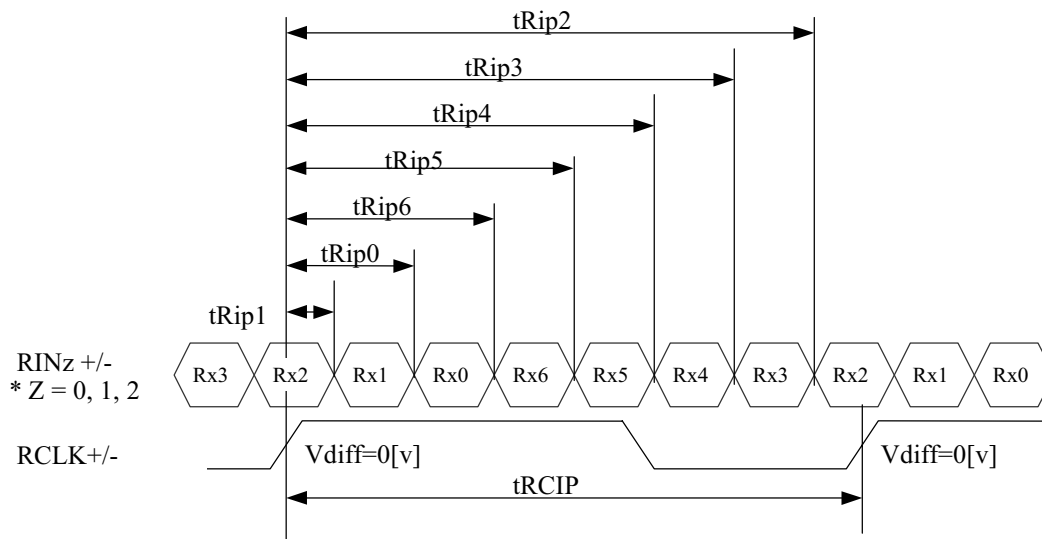

8.0 INPUT SIGNALS, BASIC DISPLAY COLORS & GRAY SCALE OF COLORS

Each color is displayed in sixty-four gray scales from a 6 bit data signal input. A total of 262,144 colors are derived from the resultant 18 bit data.

<Table 11. Input signals, Basic display colors and Gray scale of colors.>

SPEC. NUMBER

S864-1035

SPEC. TITLE

 HT12X11-100 Preliminary Product Specification for
TFT-LCD

PAGE

14 OF 24

Colors & Gray Scale		Data Signal																	
		R0	R1	R2	R3	R4	R5	G0	G1	G2	G3	G4	G5	B0	B1	B2	B3	B4	B5
Basic Colors	Black	0	0	0	0	0	0	0	0	0	0	0	0	0	0	0	0	0	0
	Blue	0	0	0	0	0	0	0	0	0	0	0	0	1	1	1	1	1	1
	Green	0	0	0	0	0	0	1	1	1	1	1	1	0	0	0	0	0	0
	Light Blue	0	0	0	0	0	0	1	1	1	1	1	1	1	1	1	1	1	1
	Red	1	1	1	1	1	1	0	0	0	0	0	0	0	0	0	0	0	0
	Purple	1	1	1	1	1	1	0	0	0	0	0	0	1	1	1	1	1	1
	Yellow	1	1	1	1	1	1	1	1	1	1	1	1	0	0	0	0	0	0
White	1	1	1	1	1	1	1	1	1	1	1	1	1	1	1	1	1	1	
Gray Scale of Red	Black	0	0	0	0	0	0	0	0	0	0	0	0	0	0	0	0	0	0
	△	1	0	0	0	0	0	0	0	0	0	0	0	0	0	0	0	0	0
	Darker	0	1	0	0	0	0	0	0	0	0	0	0	0	0	0	0	0	0
	△				↓							↓						↓	
	▽				↓							↓						↓	
	Brighter	1	0	1	1	1	1	0	0	0	0	0	0	0	0	0	0	0	0
Gray Scale of Green	Black	0	0	0	0	0	0	0	0	0	0	0	0	0	0	0	0	0	0
	△	0	0	0	0	0	0	1	0	0	0	0	0	0	0	0	0	0	0
	Darker	0	0	0	0	0	0	0	1	0	0	0	0	0	0	0	0	0	0
	△				↓							↓						↓	
	▽				↓							↓						↓	
	Brighter	0	0	0	0	0	0	1	0	1	1	1	1	0	0	0	0	0	0
Gray Scale of Blue	Black	0	0	0	0	0	0	0	0	0	0	0	0	0	0	0	0	0	0
	△	0	0	0	0	0	0	0	0	0	0	0	0	1	0	0	0	0	0
	Darker	0	0	0	0	0	0	0	0	0	0	0	0	0	1	0	0	0	0
	△				↓							↓						↓	
	▽				↓							↓						↓	
	Brighter	0	0	0	0	0	0	0	0	0	0	0	0	1	0	1	1	1	1
Gray Scale of White & Black	Black	0	0	0	0	0	0	0	0	0	0	0	0	0	0	0	0	0	0
	△	1	0	0	0	0	0	1	0	0	0	0	0	1	0	0	0	0	0
	Darker	0	1	0	0	0	0	0	1	0	0	0	0	0	1	0	0	0	0
	△				↓							↓						↓	
	▽				↓							↓						↓	
	Brighter	1	0	1	1	1	1	1	0	1	1	1	1	1	0	1	1	1	1
White	1	1	1	1	1	1	1	1	1	1	1	1	1	1	1	1	1	1	

9.0 POWER SEQUENCE

To prevent a latch-up or DC operation of the LCD module, the power on/off sequence shall be as shown in below

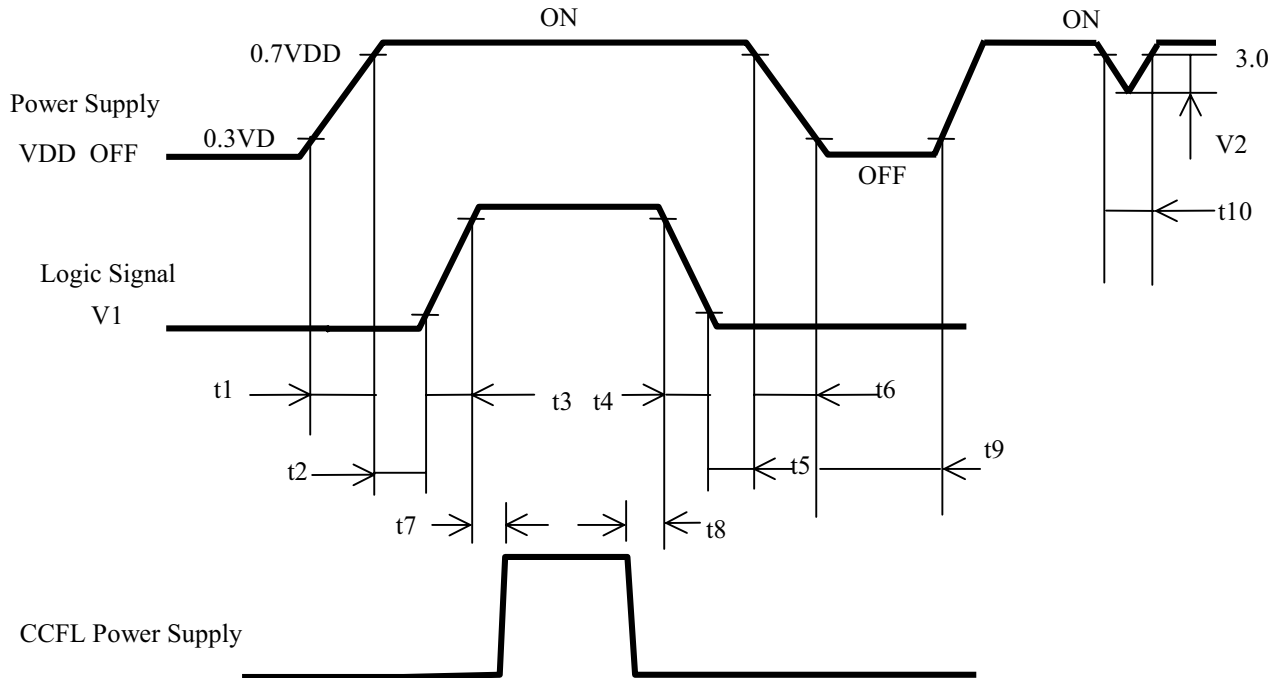

- | | |
|--------------------------------|-----------------------------------|
| $t1 \leq 10 \text{ ms}$ | $0 \leq t4 \leq 50 \text{ ms}$ |
| $0 \leq t2 \leq 50 \text{ ms}$ | $0 \leq t5 \leq 50 \text{ ms}$ |
| $0 \leq t3 \leq 50 \text{ ms}$ | $t6 \leq 10 \text{ ms}$ |
| $t7 \geq 100 \text{ ms}$ | $t8 \leq 200 \text{ ms}$ |
| $t9 \geq 1 \text{ s}$ | $t10 \leq 10 \text{ ms (Note2.)}$ |

$2.4 \text{ V} \leq V2 \leq 3.0\text{V (Note3.)}$

* SET $0\text{V} \leq V1(t) \leq VDD(t)$

HERE, $V1(t)$, $VDD(t)$ indicate the transitive state of $V1$, VDD when the power supply is turned ON or OFF

Note1. : Do not keep the interface signal high-impedance when power is on.

Note2. : Momentary Voltage Drop Time.

Note3. : Momentary Drop Voltage.

10.0 MECHANICAL CHARACTERISTICS

10.1 Dimensional Requirements

<Table 12. Dimensional Parameters.>

Parameter	Specification	Unit
Active area	245.8 (H) * 184.3 (V)	mm
Number of pixels	1024 (H) * 768 (V)	pixels
	(1 pixel = R + G + B dots)	
Pixel pitch	0.240 (H) * 0.240 (V)	mm
Pixel arrangement	RGB Vertical stripe	
Display colors	262,144	colors
Display mode	Normally white	
Dimensional outline	261.0 ± 0.5(H) * 199.0 ± 0.5(V) * 5.6 (D) typ. / 5.9 (D) max.	mm
Weight	400 Typ.	gram
Back-light	CCFL, Horizontal-lamp type	

See FIGURE 6. (shown in Appendix)

10.2 Mounting

See FIGURE 7. (shown in Appendix)

10.3 Anti-Glare and Polarizer Hardness.

The surface of the LCD has an anti-glare coating to minimize reflection and a coating to reduce scratching.

10.4 Light Leakage

There shall not be visible light from the back-lighting system around the edges of the screen as seen from a distance 50cm from the screen with an overhead light level of 350lux.

11.0 RELIABILITY TEST

<Table 13. Reliability test>

No	Test Items	Conditions
----	------------	------------

	PRODUCT GROUP	REV.	ISSUE DATE
	TFT-LCD PRODUCT	P0	2000.4.25

1	High temperature storage test	Ta = 60 °C, 240 hrs
2	Low temperature storage test	Ta = -20 °C, 240 hrs
3	High temperature & high humidity operation test	Ta = 50 °C, 80 %RH, 240 hrs
4	High temperature operation test	Ta = 50 °C, 240 hrs
5	Low temperature operation test	Ta = 0 °C, 240 hrs
6	Thermal shock	Ta = -20 °C ↔ 60 °C (0.5 hr), 100 cycle
7	Vibration test (non-operating)	Frequency : 10 ~ 500 Hz Gravity/AMP : 1.5G X,Y,Z Period : 15 min
8	Shock test (non-operating)	Gravity : 70 G Pulse width : 11 ms, half sine wave Direction : ±X, ±Y, ±Z once for each direction
9	Electrostatic discharge test	Air : 150 pF, 330Ω, 15 KV Contact : 150 pF, 330Ω, 8 KV

Result Evaluation Criteria

Under the display quality test conditions with normal operation state, there shall be no change which may affect practical display function.

12.0 HANDLING & CAUTIONS

(1) Cautions when taking out the module

- Pick the pouch only, when taking out module from a shipping package.

(2) Cautions for handling the module

SPEC. NUMBER S864-1035	SPEC. TITLE HT12X11-100 Preliminary Product Specification for TFT-LCD	PAGE 18 OF 24
---------------------------	---	------------------

	PRODUCT GROUP	REV.	ISSUE DATE
	TFT-LCD PRODUCT	P0	2000.4.25

- As the electrostatic discharges may break the LCD module, handle the LCD module with care. Peel a protection sheet off from the LCD panel surface as slowly as possible.
- As the LCD panel and back - light element are made from fragile glass material, impulse and pressure to the LCD module should be avoided.
- As the surface of the polarizer is very soft and easily scratched, use a soft dry cloth without chemicals for cleaning.
- Do not pull the interface connector in or out while the LCD module is operating.
- Put the module display side down on a flat horizontal plane.
- Handle connectors and cables with care.

(3) Cautions for the operation

- When the module is operating, do not lose CLK, ENAB signals. If any one of these signals is lost, the LCD panel would be damaged.
- Obey the supply voltage sequence. If wrong sequence is applied, the module would be damaged.

(4) Cautions for the atmosphere

- Dew drop atmosphere should be avoided.
- Do not store and/or operate the LCD module in a high temperature and/or humidity atmosphere. Storage in an electro-conductive polymer packing pouch and under relatively low temperature atmosphere is recommended.

(5) Cautions for the module characteristics

- Do not apply fixed pattern data signal to the LCD module at product aging.
- Applying fixed pattern for a long time may cause image sticking.

(6) Other cautions

- Do not disassemble and/or re-assemble LCD module.
- Do not re-adjust variable resistor or switch etc.
- When returning the module for repair or etc., Please pack the module not to be broken. We recommend to use the original shipping packages.

13.0 PACKING INFORMATION

HEI provides the standard shipping container for customers, unless customer specifies their packing information. (TBD)

14.0 APPENDIX

Figure 1. Measurement Set Up

SPEC. NUMBER S864-1035	SPEC. TITLE HT12X11-100 Preliminary Product Specification for TFT-LCD	PAGE 19 OF 24
---------------------------	---	------------------

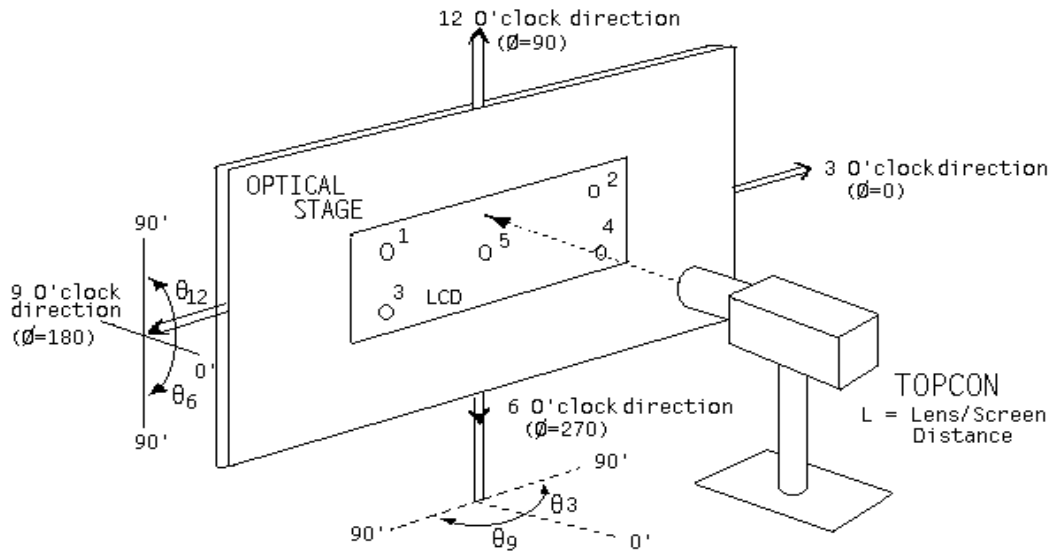

Figure 2. Average Luminance Measurement Locations

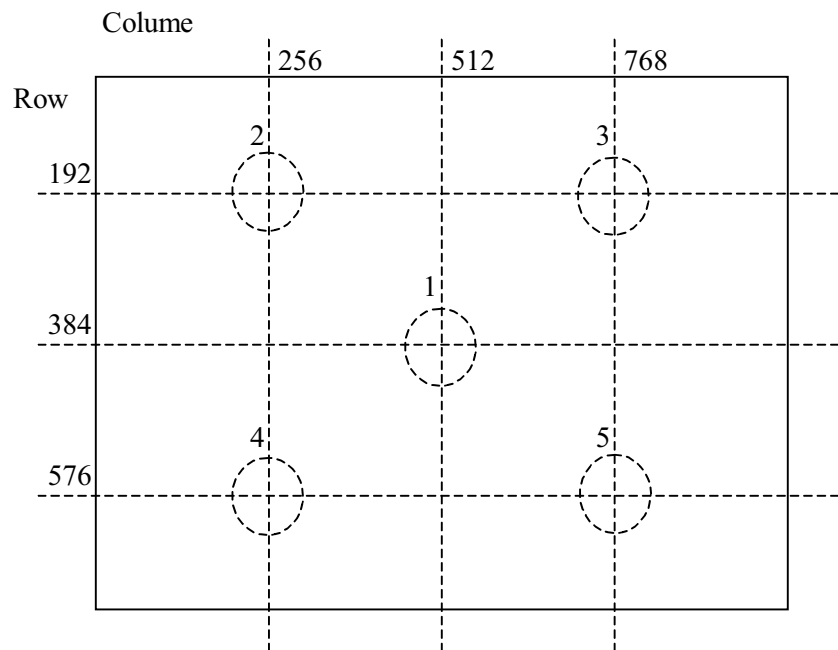

Figure 3. Uniformity Measurement Locations

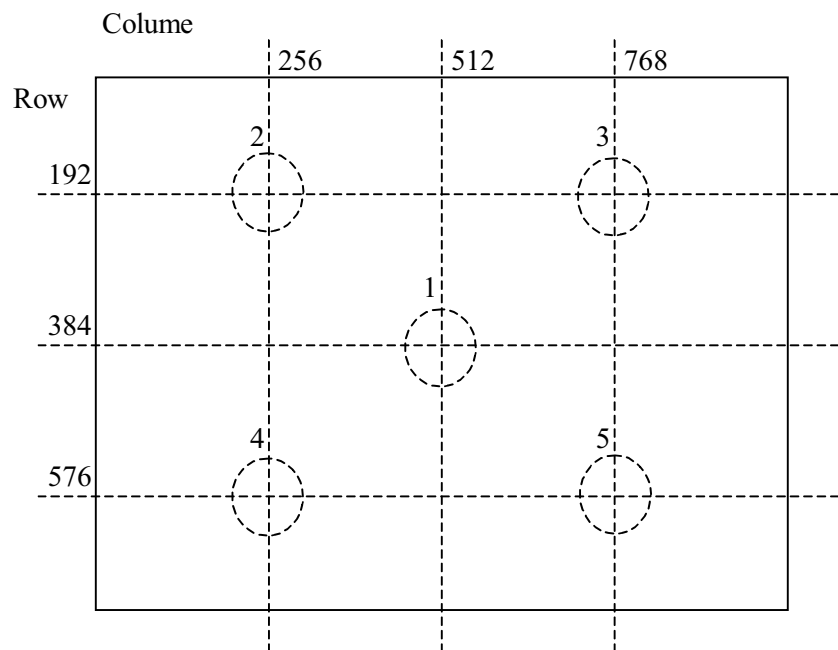

Figure 4. Response Time Testing

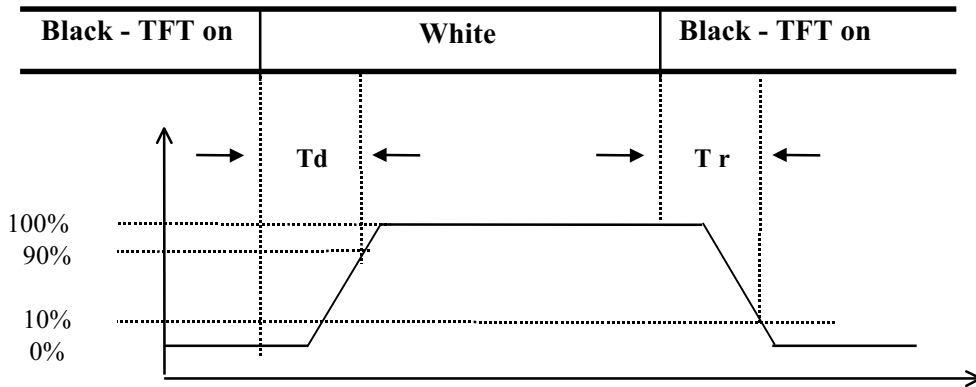
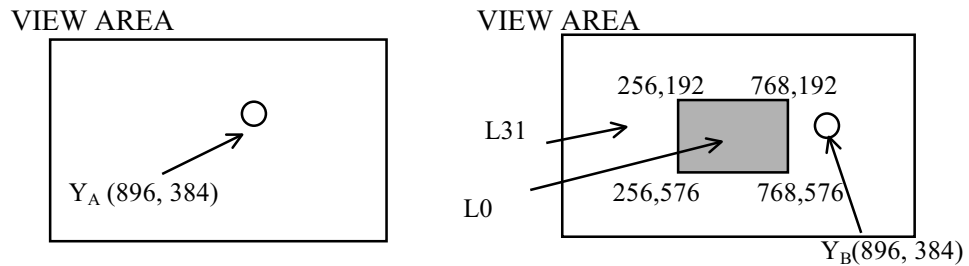

Figure 5. Cross Modulation Test Description



$$\text{Cross-Talk(\%)} = \left| \frac{Y_B - Y_A}{Y_B} \right| \times 100$$

Where:

Y_A = Initial luminance of measured area (cd/m^2)
 Y_B = Subsequent luminance of measured area (cd/m^2)
 The location measured will be exactly the same in both patterns

Figure 6. TFT-LCD Module Outline Dimensions (Front view)

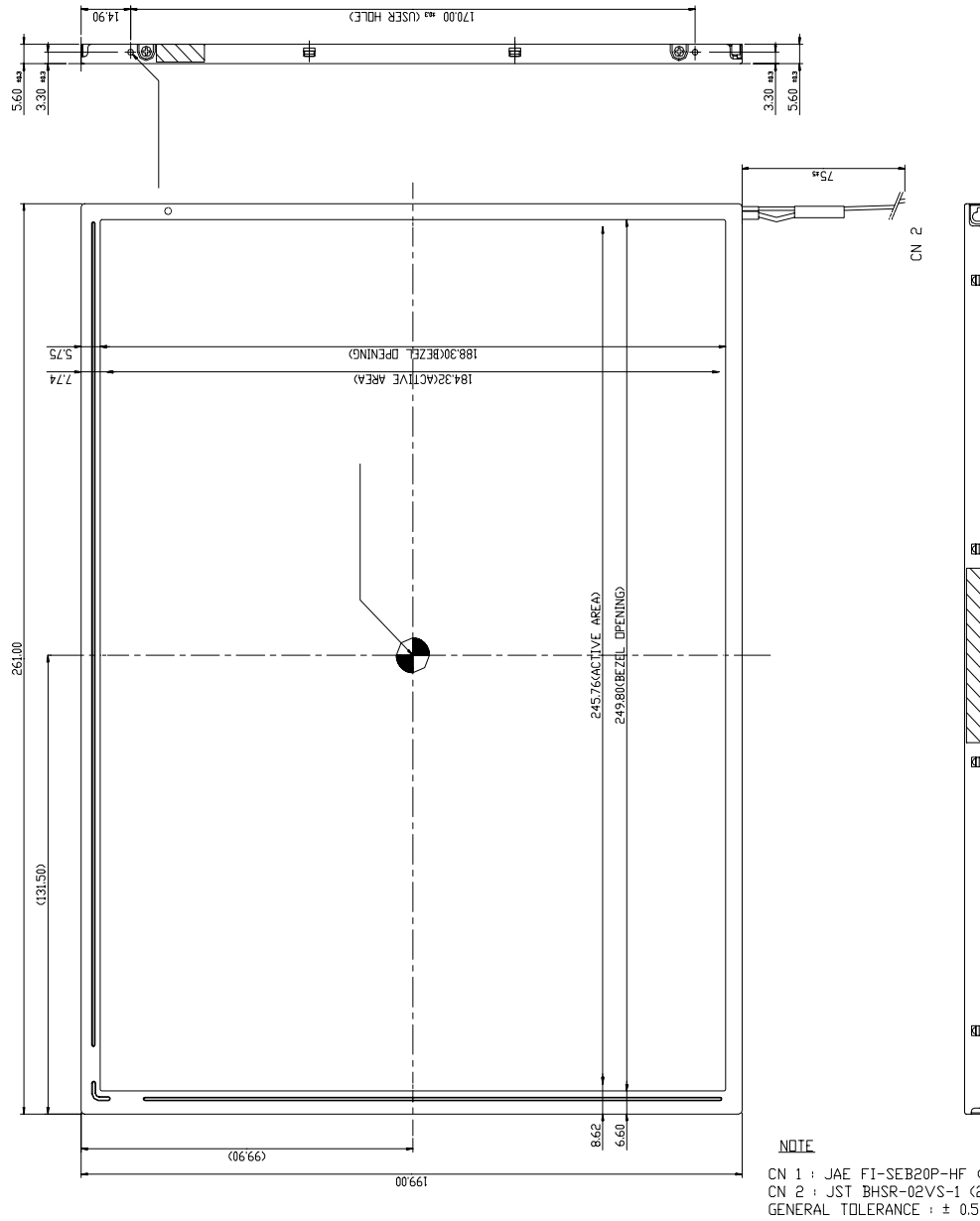

Figure 7. TFT-LCD Module Outline Dimensions (Back view)

SPEC. NUMBER	SPEC. TITLE	PAGE
S864-1035	HT12X11-100 Preliminary Product Specification for TFT-LCD	23 OF 24

SPEC. NUMBER	SPEC. TITLE	PAGE
S864-1035	HT12X11-100 Preliminary Product Specification for TFT-LCD	23 OF 24

SPEC. NUMBER	SPEC. TITLE	PAGE
S864-1035	HT12X11-100 Preliminary Product Specification for TFT-LCD	23 OF 24



PRODUCT GROUP

REV.

ISSUE DATE

TFT-LCD PRODUCT

P0

2000.4.25

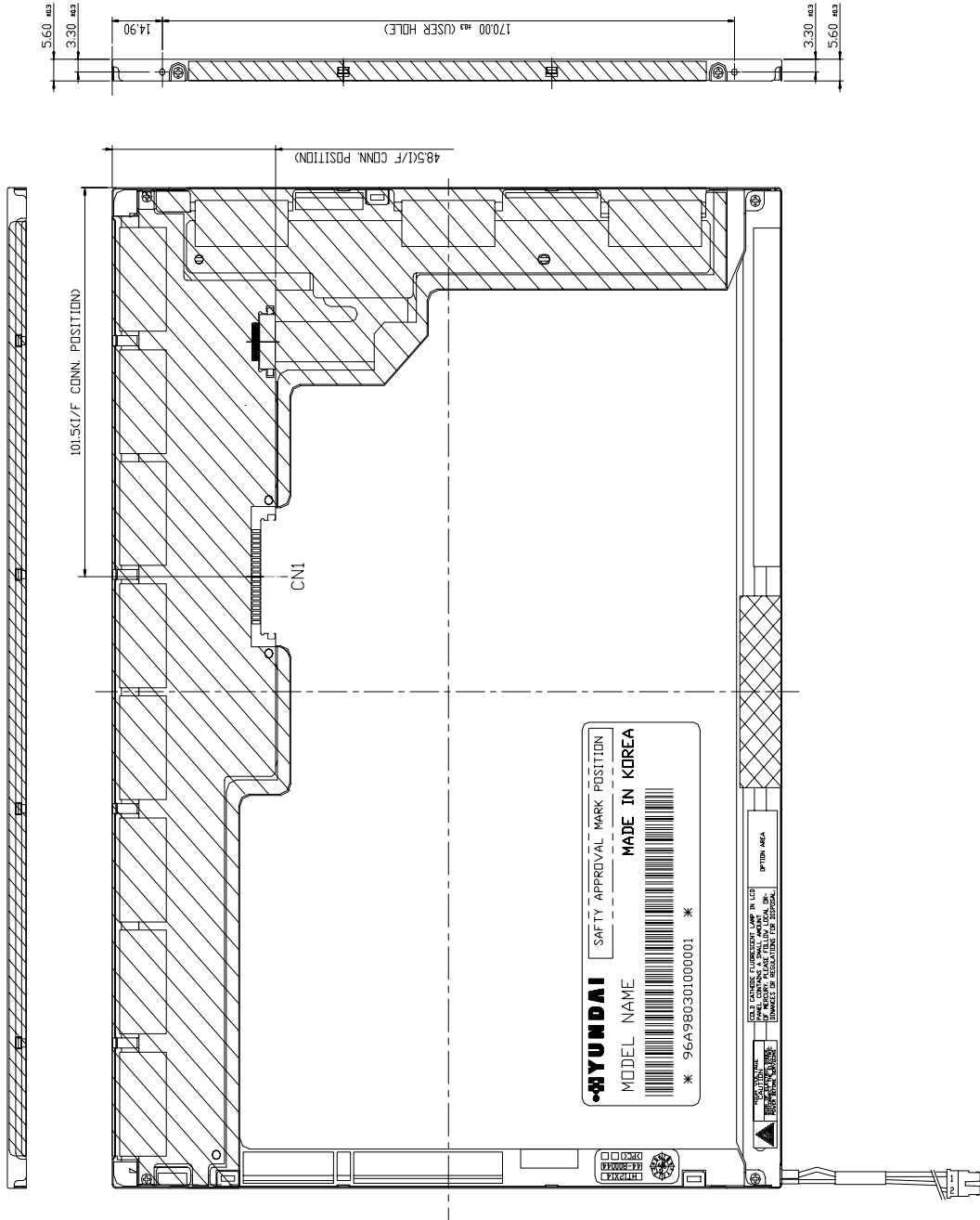

SPEC. NUMBER
S864-1035

SPEC. TITLE
HT12X11-100 Preliminary Product Specification for
TFT-LCD

PAGE
24 OF 24